

BAR	A
4'	51"
5'	65"
6'	82"
7'	93"
8'	103"

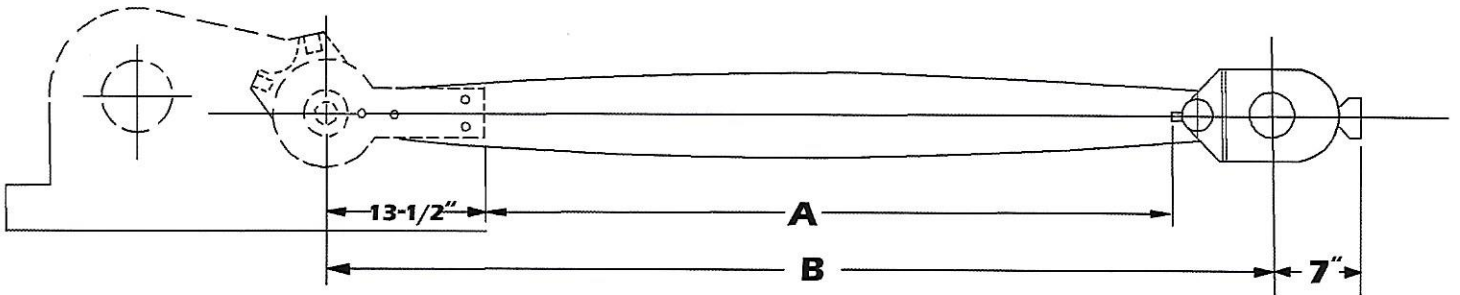

POND & DECK SAW		DATA SHEET		
BAR	A	B	ACTUAL LENGTH	PART #
4'	36"	58"	51"	5051-DE
5'	50"	72"	65"	5065-DE
6'	67"	89"	82"	5082-DE
7'	78"	100"	93"	5093-DE
8'	88"	110"	103"	5103-DE
9'	99"	121"	114"	5114-DE
10'	109"	131"	124"	5124-DE
12'	134"	156"	149"	5149-DE

CUSTOM LENGTHS WELCOMED

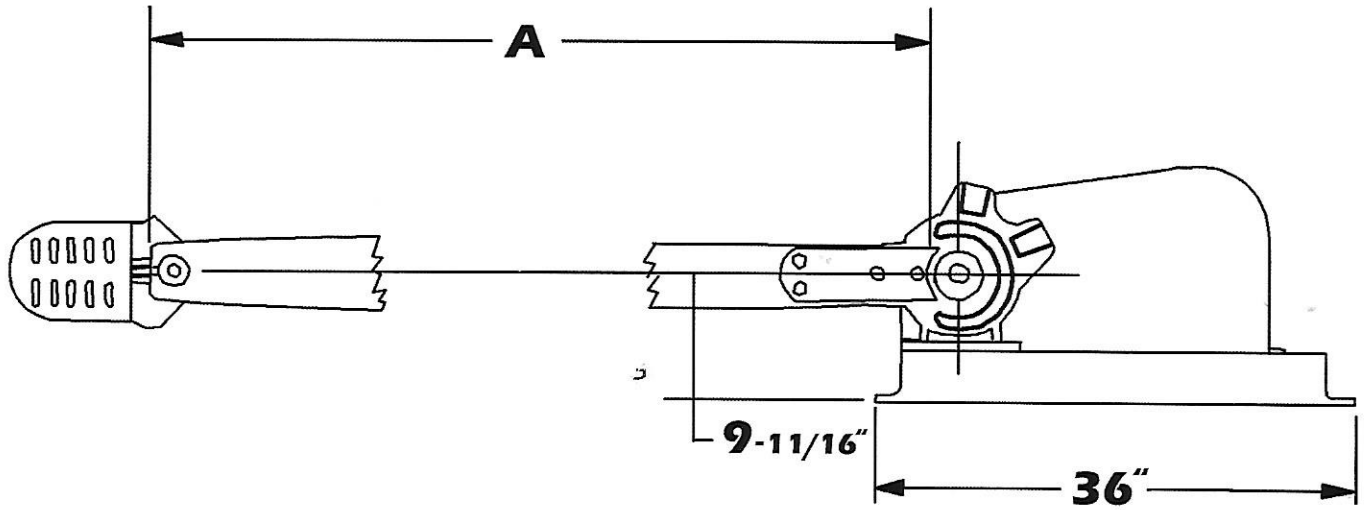
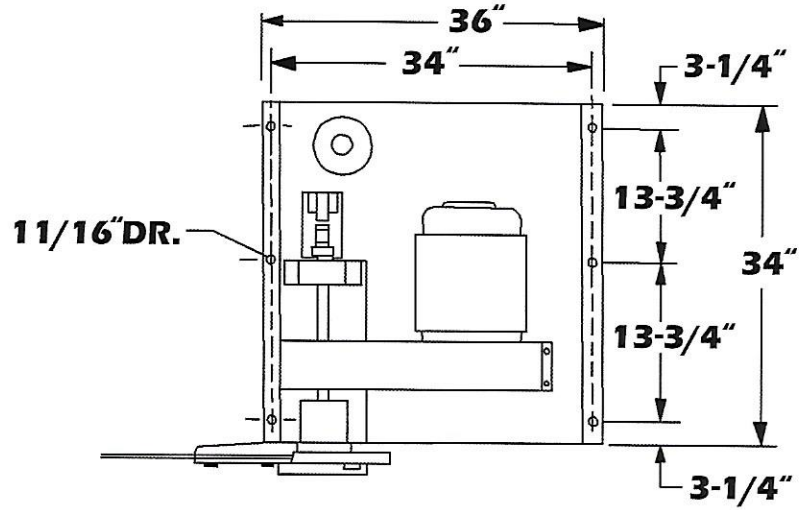
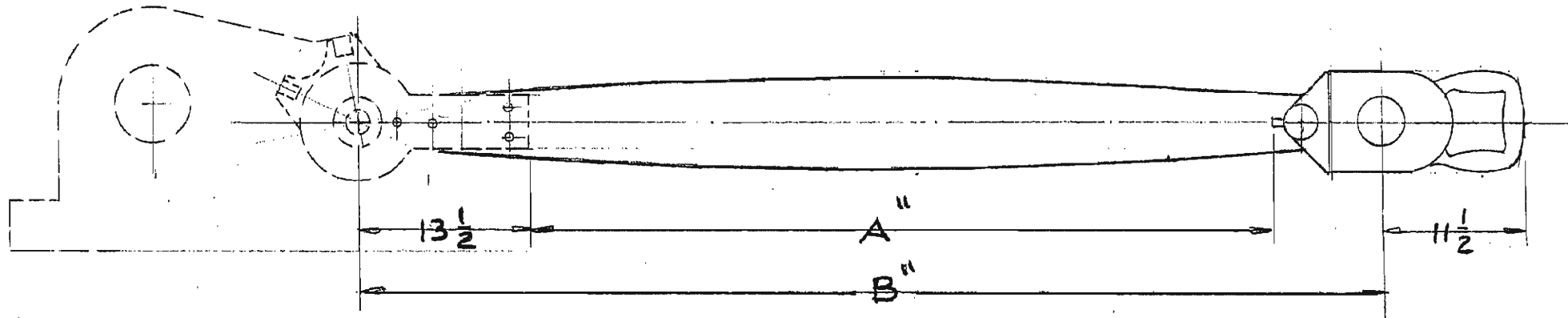

BAR	A	B	ACTUAL LENGTH	PART N°
4 FT	36	58	51	5051-DE
5	50	72	65	5065-DE
6	67	89	82	5082-DE
7	78	100	93	5093-DE
8	88	110	103	5103-DE
10	109	131	124	5124-DE
12	134	156	149	5149-DE

4				DRAWN S40	CHKD.	SCALE	SERINGE
3				MATERIAL		MACHINE POND & DECK SAW	
2				STOCK SIZE			DATE
1				DIE OR PATT.		SUBJECT DATA SHEET	IP3177
NO.	CHANGE	DATE	BY	FINISHED FRACTIONAL DIMENSIONS ± .010			

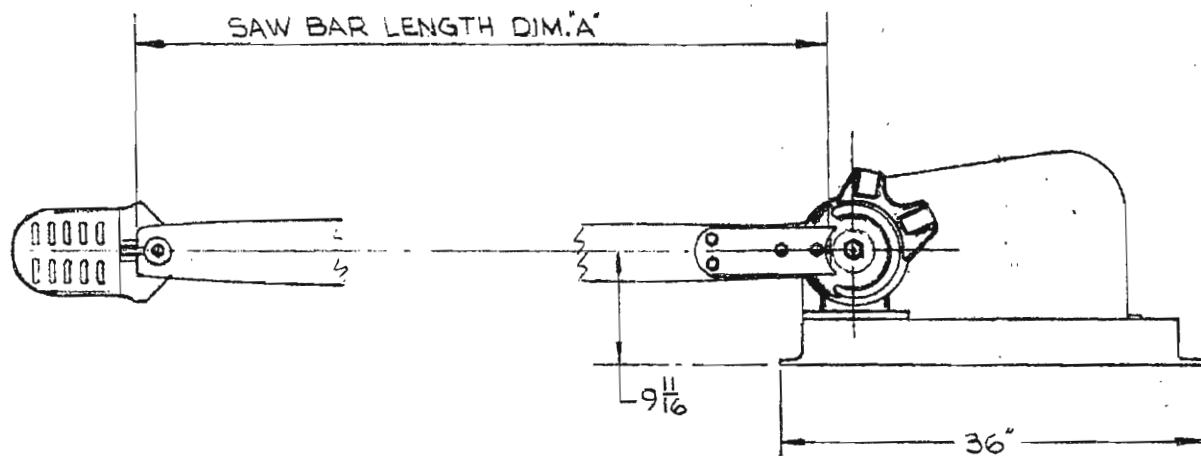
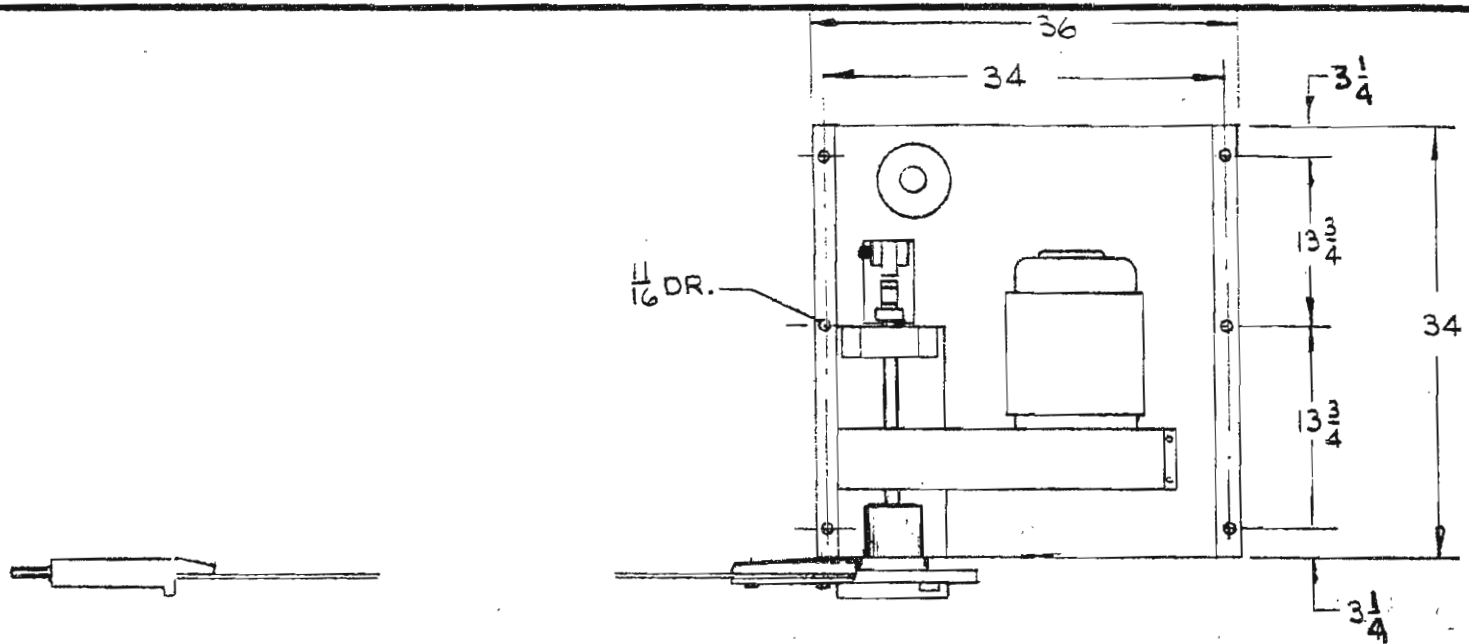

8 FT	103"
7 FT	93"
6 FT	82"
5 FT.	65"
4 FT.	51"
SIZE BAR	SAW BAR LEN. "A"

POND OR DECK SAW

4				DRAWN SE.PING	CHKD.	SCALE 3/4" = 1'-0"	BLUE BASE
3				MATERIAL		MACHINE	
2				STOCK SIZE		DECK SAW	DATE
1				DIE OR PATT.		SUBJECT	
NO.	CHANGE	DATE	BY	FINISHED FRACTIONAL DIMENSIONS ± .010		SETTING PLAN	A-23205